

DIESEL FUEL PUMPS

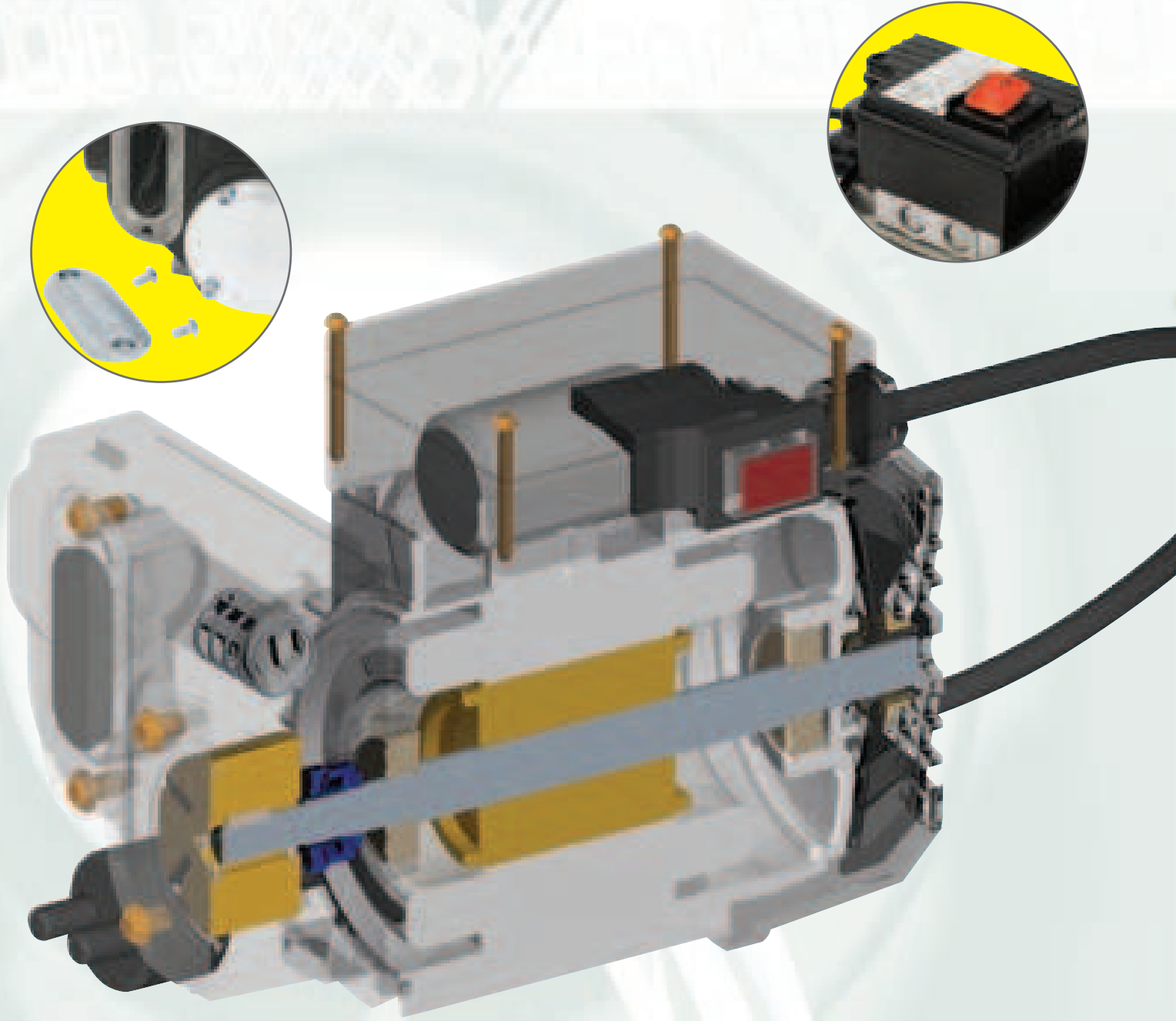

ELECTRIC PUMPS 12/24 volt DC

"EASY" range with aluminum pump body



DP3517 - 30 lt/' - 12 Volt

DP3518 - 30 lt/' - 24 Volt

Self-priming rotary vane electric pump, with bypass valve, pumping system in anodized aluminum, rotor vanes are Delrin, flow rate of 30 Lt/'. Maximum 30' duty cycle - max delivery pressure 0,25 BAR

	VOLT	AMP	lt/'	IN	OUT	RPM		cm	INCLUDES
DP3517	12	13	30	3/4"	3/4"	3500	4,2	19x33x16	cables 1,8 mt -clamps - on /off switch
DP3518	24	7	30	3/4"	3/4"	3500	4,2	19x33x16	

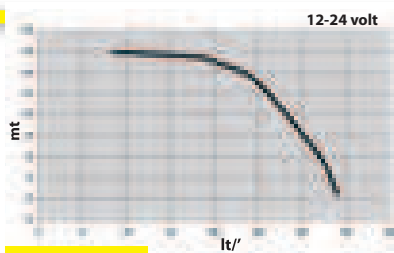

DP 3004-3005

"STANDARD" range with pump body in cast iron

Self-priming rotary vane electric pump, with bypass valve, pump body is cast iron with anti-corrosion treatment and paint. Ideal for the transfer of diesel fuel on earth-moving machinery, in agriculture or construction yards. 12 /24 volts DC motors. Simple and complete with all accessories. Flow rate from 40 to 78 lt/'. Duty cycle 30' max., suction capacity 2,5 meters

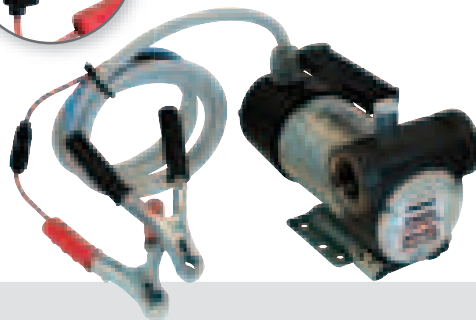

DP3504 - 40 lt/' - 12 Volt

DP3505 - 40 lt/' - 24 Volt

DP3506 - 40 lt/' - 12 Volt

DP3507 - 40 lt/' - 24 Volt

DP3514 - 56 lt/' - 12 Volt

DP3515 - 56 lt/' - 24 Volt

DP3509 - 78 lt/' - 12 Volt

DP3510 - 78 lt/' - 24 Volt

	VOLT	AMP	lt/'	IN	OUT	RPM		cm	INCLUDES
DP3504	12	13	40	1"	1"	3500	3,1	19x33x16	mounting bracket
DP3505	24	7	40	1"	1"	3500	3,1	19x33x16	mounting bracket
DP3506	12	13	40	1"	1"	3500	4,2	19x33x16	mounting bracket - cables 1,8 mt - clamps - on /off switch - external fuse - handle
DP3507	24	7	40	1"	1"	3500	4,2	19x33x16	mounting bracket - cables 1,8 mt - clamps - on /off switch - external fuse - handle
DP3514	12	34	56	1"	1"	3500	8,45	19x35x27	mounting bracket - cables 1,8 mt - clamps - on /off switch - power relay - filter - handle
DP3515	24	17	56	1"	1"	3500	8,45	19x35x27	mounting bracket - cables 1,8 mt - clamps - on /off switch - power relay - filter - handle
DP3509	12	34	78	1"	1"	3500	10,5	19x35x27	mounting bracket - cables 1,8 mt - clamps - on /off switch - power relay - filter - handle
DP3510	24	17	78	1"	1"	3500	10,5	19x35x27	mounting bracket - cables 1,8 mt - clamps - on /off switch - power relay - filter - handle

ELECTRIC PUMPS 230 - 400 Volt 50 Hz

"EASY" range with aluminum pump body

Self-priming electric vane pump with anodized aluminum pump body and bypass valve with acetal resin rotor. Protection grade IP 55. Suction capacity 3 meters - max delivery pressure 1,8 BAR.

"STANDARD" range with cast iron pump body

Self-priming electric vane pump with cast iron pump body, anti-corrosion treatment and paint, special ceramic rotary seal, bypass valve, 100 micron suction screen. Protection grade IP 55. Suction capacity 3mt - max delivery pressure 2,8 BAR

DP3512 - 48 lt/' - 230 Volt



DP3501 - 56 lt/' - 230 Volt

DP3502 - 74 lt/' - 230 Volt



DP3519 - 48 lt/' - 400 Volt

DP3520 - 56 lt/' - 400 Volt

DP3521 - 74 lt/' - 400 Volt

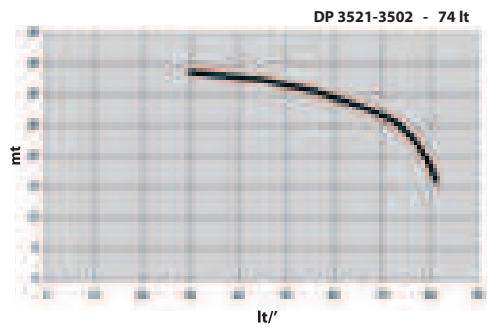
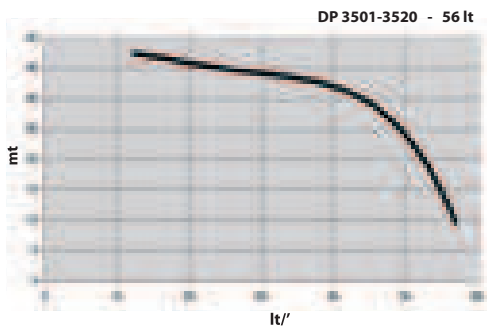

	VOLT	W	LT/'	IN	OUT	RPM		cm	INCLUDES	
E A S Y	DP3512	230	350	48	1"	1"	2800	7,00	19x35x27	on /off switch - supply power cable with schuko plug*
	DP3519	400	350	48	1"	1"	2800	7,00	19x35x27	
S T A N D A R D	DP3501	230	350	56	1"	1"	2800	7,60	19x35x27	on /off switch - supply power cable with schuko plug*
	DP3502	230	400	74	1"	1"	2800	11,4	19x35x27	on /off switch - supply power cable with schuko plug*
	DP3520	400	350	56	1"	1"	2800	7,60	19x35x27	
	DP3521	400	400	74	1"	1"	2800	11,4	19x35x27	

N.B. All electric pumps with 400 volts power supply are delivered WITHOUT cable, socket and switch

ELECTRIC PUMPS 230-400 Volt 50 Hz

"HIGH VOLUME" Pumps with cast iron body

"HIGH VOLUME" range with aluminum pump body

Self-priming electric vane pump with cast iron pump body and anti-corrosion treatment, special ceramic rotary seal, bypass valve . Protection grade IP 55. Suction 3mt - max delivery pressure 2,8 BAR. Possibility of flanged connectors.

Self-priming electric vane pump ideal for high volume diesel transfers . Body has an anodized aluminum finish to provide protection against oxidation. Has a steel rotor with acetal resin vanes, ceramic seal and built in by-pass valve . Pump includes an internal suction filter.



- DP3508** - 85 lt/' - 230 Volt
- DP3503** - 100 lt/' - 230 Volt
- DP3511** - 120 lt/' - 230 Volt
- DP3513** - 150 lt/' - 230 Volt

DP3516 - 200 lt/' - 230 Volt



- DP3522** - 85 lt/' - 400 Volt
- DP3523** - 100 lt/' - 400 Volt
- DP3524** - 120 lt/' - 400 Volt
- DP3525** - 150 lt/' - 400 Volt

DP3526 - 200 lt/' - 400 Volt

	VOLT	W	LT/'	IN	OUT	RPM		 cm	INCLUDES	
A L T O	DP3508	230	0,9	85	1" F	1" F	1400	21,00	23x40x25	on /off switch supply power cable with schuko plug*
	DP3503	230	1,1	100	1 1/4" F	1 1/4" F	1400	23,00	23x40x25	
	DP3511	230	1,5	120	1 1/4" F	1 1/4" F	1400	23,00	23x40x25	
	DP3513	230	1,85	150	1 1/4" F	1 1/4" F	1400	23,00	23x40x25	
	DP3516	230	2,25	200	2" M	2" M	1400	36,00	30x55x30	
V O L U M E	DP3522	400	0,90	85	1" F	1" F	1400	21,00	23x40x25	
	DP3523	400	1,10	100	1 1/4" F	1 1/4" F	1400	23,00	23x40x25	
	DP3524	400	1,50	120	1 1/4" F	1 1/4" F	1400	23,00	23x40x25	
	DP3525	400	1,85	150	1 1/4" F	1 1/4" F	1400	23,00	23x40x25	
	DP3526	400	2,25	200	2" M	2" M	1400	36,00	30x55x30	

N.B. All electric pumps with 400 volts power supply are delivered WITHOUT cable, socket and switch

SPECIAL PUMPS

PNEUMATIC DIAPHRAGM PUMP

Ideal for diesel fuel transfer. Has an aluminium body with max delivery pressure 7 bar. Flow rate from 30 lt./' to 150 lt./'. All pumps are certified ATEX zone 2 -EX II 3/3GD c IIB T135°C

DP1001 - 1/2" - 30 lt/'



DP1002 - 1/2" - 50 lt/'

DP1003 - 1" - 150 lt/'



X0279

Bracket for wall mount installation of pneumatic pumps

		DP1001	DP1002	DP1003
Ratio A 6 BAR	lt/'	30	50	150
	gal/'	7,9	13,2	39,5
Delivery pressure	bar	2,5 - 7	2,5 - 7	2,5 - 7
	psi	36 - 100	36 - 100	36 - 100
Air connection		1/4"	3/8"	1/2"
IN-OUT connection		1/2"	1/2"	1"
Noise	dB	80	80	80
Max air consumption	lt/'	350	500	2000
	Kg	2	4	8,2
	cm	17x15x23	23x31x33	25x39x36

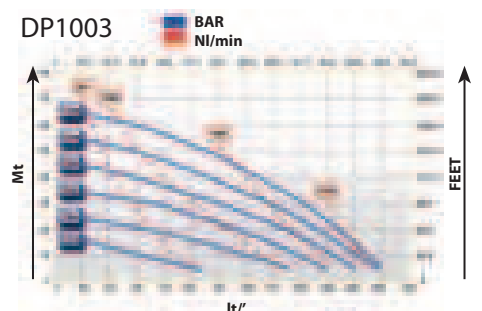
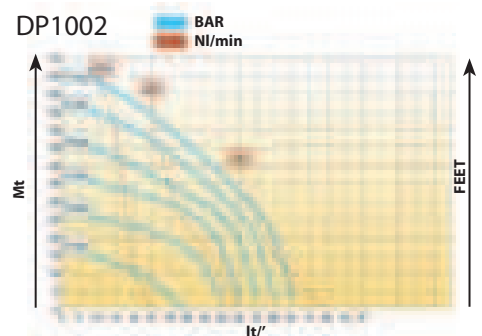
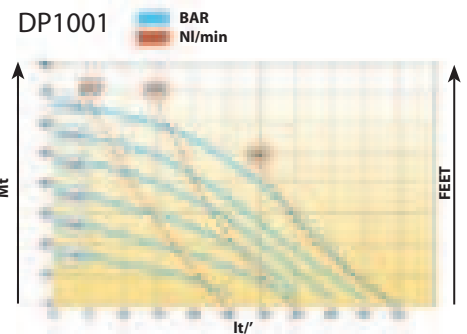

HAND PUMPS

NP2001

manual double-acting piston pump - telescoping suction tube for 50/200lt drums - flow rate 30lt./'

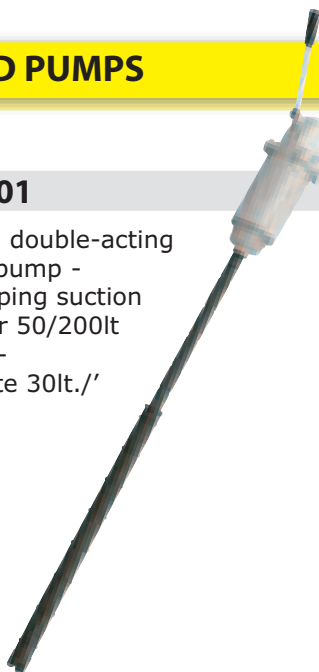

NP2018

Manual rotary cast iron pump - includes rigid suction tube and bung adaptor - 50/200lt drums flow rate 40lt./'

